



**NAME: LED ShoeBox Light**

**P/N: SNC-NSB-400W**

Note: The Letter X in P/N stands for  
 01: ADJUSTABLE FITTER MOUNTING  
 02: DIRECT MOUNTING  
 03: YOKE MOUNTING

**Advantage:**

- UL cUL certificate
- PHILIPS Chip, high CRI
- Mean Well IP65 driver, input voltage 100-277VAC
- No UV or IR in the beam
- Easy to install and operate
- Energy saving, long lifespan
- Light is soft and uniform, safe to eyes
- Instant start, NO flickering, NO humming
- Green and eco-friendly without mercury.

**Application:**

- 1. Outdoor basketball court, tennis court.
- 2. Badminton court, the football field.
- 3. The school playground, stadium.
- 4. Community leisure entertainment plaza, road lamp etc.

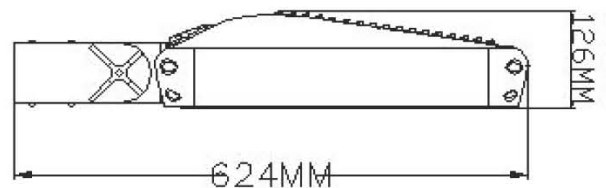
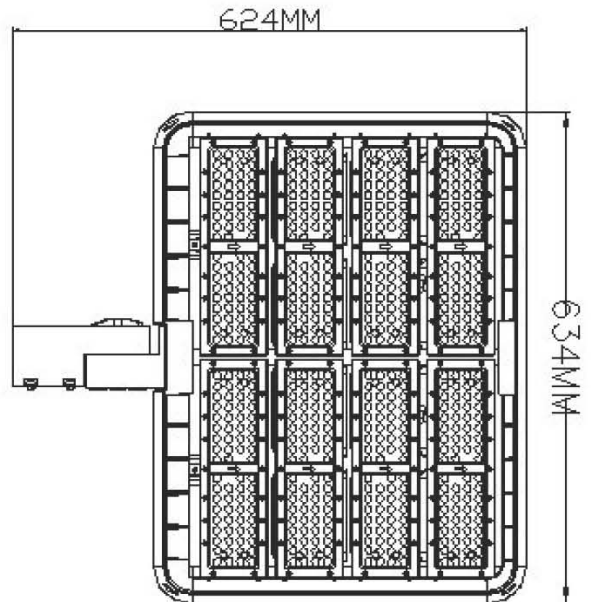

**Product Specifications**

Product name	LED Shoe Box Light		
Part No	SNC-NSB-400W		
Light Type	Shoe Box Light		
Dimension	624*634*126mm		

**Technical Characteristic**

Color temperature	2700K - 7000K		
CRI	>70		
Lumen	37500-39000LM		
Input Power	400W		
Viewing Angle	150*85 Degree (Type III)		
Input Voltage	100-277V 50/60Hz		
Driver model	HLG-320H-48A ( Mean Well Driver )		
PFC	>0.9		
Waterproof Rating	IP65		

**Materials**

LED Brand	PHILIPS		
LED Type	3030, 1.5W		
LED QTY	560		
Housing	Aluminum		
Housing color	Black		
Operating Temperature	-20°C TO 45°C		
Operating Humidity	20%-90% RH		
Storage Temperature	-30°C TO 80°C		

**Others**

Storage Humidity	10%-95%		
Application	Outdoor		
Safety Certification	UL、cUL		
Warranty Time	5 Years		

## Light Distribution Testing Parameters

DATA OF LAMP		PHOTOMETRIC DATA <span style="float: right;">Eff: 131.81 lm/W</span>			
MODEL		I <sub>max</sub> (cd)	21550	S/MH (C0/180)	1.38
NOMINAL POWER (W)	400w	LOR (%)	100.0	S/MH (C90/270)	0.82
RATED VOLTAGE (V)	220	TOTAL FLUX (lm)	50477	η UP, DN (C0-180)	0.0, 67.7
NOMINAL FLUX (lm)	50477	CIE CLASS	DIRECT	η UP, DN (C180-360)	0.0, 32.3
LAMPS INSIDE	1	η up (%)	0.0	CIBSE SHR NOM	1.50
TEST VOLTAGE (V)	220	η down (%)	100.0	CIBSE SHR MAX	1.55

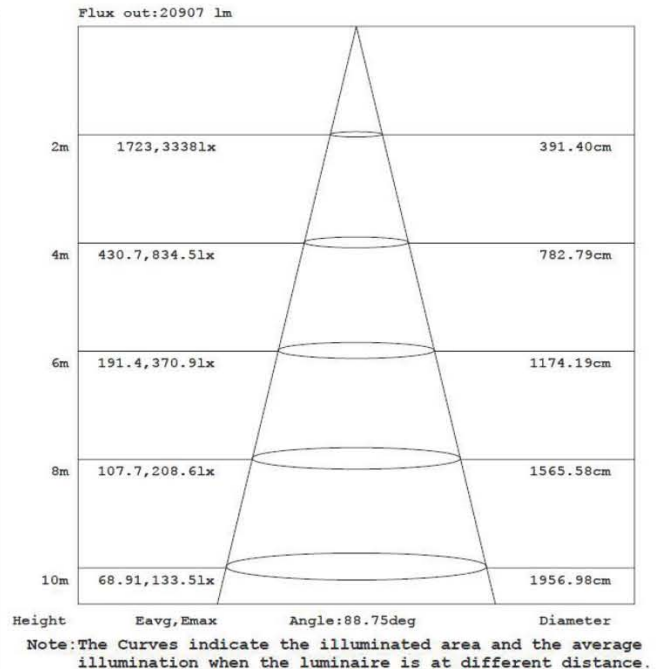
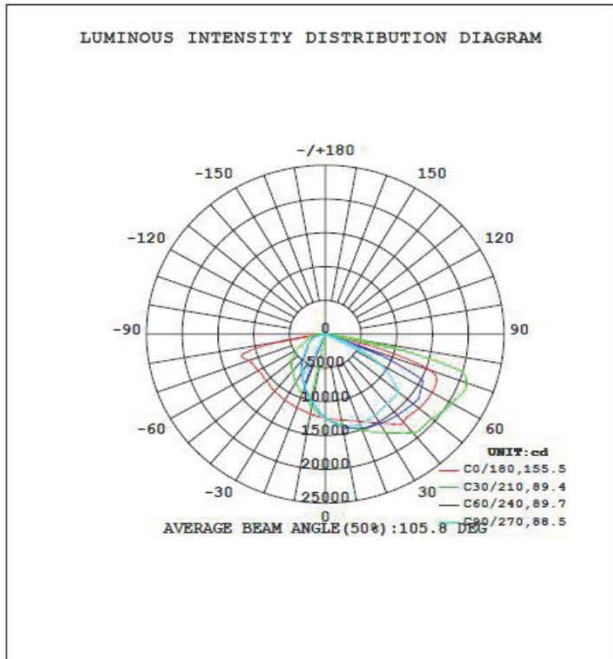

**Package**

**Lamps Net Weight: 15.3Kg/pcs**

	Size	Qty/Carton	Weight/Carton
Outer box	715*705*195mm	1	20.5 kg

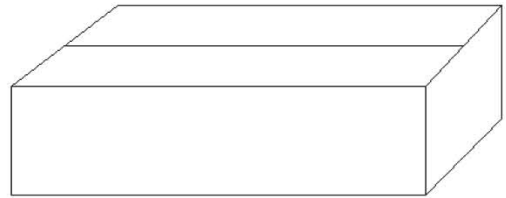
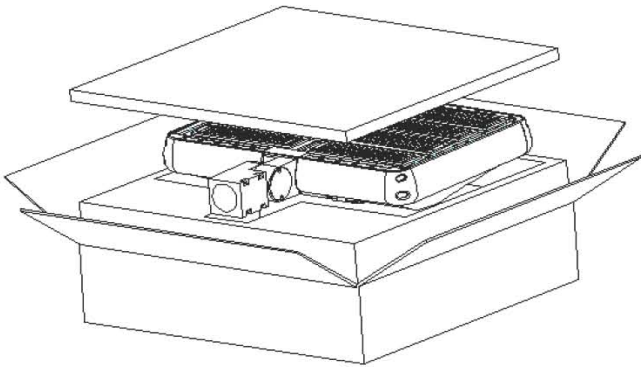

**Notice For User**

- ◆ Please turn off power before installation or maintenance
- ◆ The input voltage and lamps should be matched, after connecting the power line  
Please make sure the wiring section is insulated
- ◆ DO NOT alter or tamper with or modify the lamps or lamp housing

**Trouble Shooting**

Troubles	Check points
Flickering of the light	Turn off the power and turn on again in 3 minutes. If same phenomena occur, then call agencies
Out of working	Please check the connection